

# RODOBAL

SNODI SFERICI - SPHERICAL BEARINGS - ROTULES - DIN 648 E - DIN ISO 2240-1

SENZA MANUTENZIONE

MAINTENANCE FREE

SANS ENTRETIEN



SERIE STRETTA DIN 648E

NARROW SERIES DIN 648 E

SERIES ETROITE DIN 648 E

SERIE GE..SEJR  
GE..SEJR-2RS

SERIES GE..SEJR  
GE..SEJR-2RS

SERIE GE..SEJR  
GE..SEJR-2RS

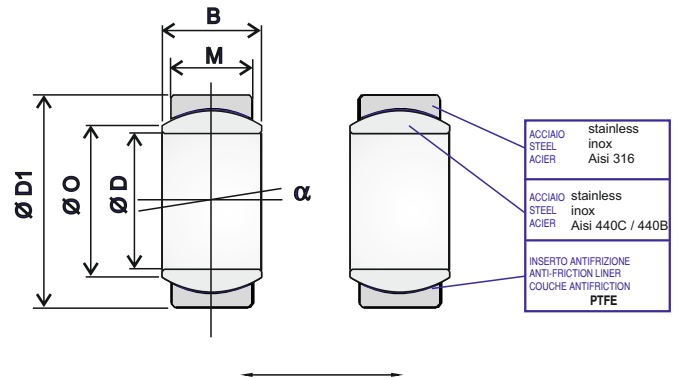

TIPO TYPE TYPE	ØD	ØD1	B	M	α°	ØO	S Ø DB	CARICO - LOAD MAX. Co-kN		PESO WEIGHT POIDS
								STAT.	DYN.	
GE 6 SEJR	6	14	6	4	13°	8,0	10,0	9	4	4 g
GE 8 SEJR	8	16	8	5	15°	10,2	13,0	15,6	7	7 g
GE 10 SEJR	10	19	9	6	12°	13,2	16,0	23,4	10	11 g
GE 12 SEJR	12	22	10	7	11°	15,0	18,0	32	14	16 g
GE 15 SEJR	15	26	12	9	8°	18,4	22,0	50	30	26 g
GE 16 SEJR	16	30	14	10	8°	20,7	25,0	65	39	38 g
GE 17 SEJR	17	30	14	10	10°	20,7	25,0	65	39	49 g
GE 20 SEJR	20	35	16	12	9°	24,2	29,0	90,5	54	61 g
GE 25 SEJR	25	42	20	16	7°	29,3	35,5	159	96	110 g
GE 30 SEJR	30	47	22	18	6°	34,2	40,7	197	118	140 g
GE 35 SEJR	35	55	25	20	6°	39,8	47,0	298	153	220 g
GE 40 SEJR (-2RS)	40	62	28	22	7°	45,0	53,0	370,6	190	300 g
GE 45 SEJR (-2RS)	45	68	32	25	7°	50,8	60,0	481	247	400 g
GE 50 SEJR (-2RS)	50	75	35	28	6°	56,0	66,0	598	308	540 g
GE 60 SEJR (-2RS)	60	90	44	36	6°	66,8	80,0	940	481	1000 g
GE 70 SEJR (-2RS)	70	105	49	40	6°	77,9	92,0	1204	619	1500 g
GE 80 SEJR (-2RS)	80	120	55	45	6°	89,4	105,0	1540	792	2200 g
GE 90 SEJR (-2RS)	90	130	60	50	5°	98,0		1892	1080	2700 g
GE 100 SEJR (-2RS)	100	150	70	55	7°	109,0		2366	1350	4400 g
GE 110 SEJR (-2RS)	110	160	70	55	6°	121,0		2548	1460	4700 g
GE 120 SEJR (-2RS)	120	180	85	70	6°	135,0		3752	2140	8000 g

Vid inbyggning i motorsport använd om möjligt den mer anpassade serien "MTE".

Lagerglapp: Radiellt och axiellt spel 0,030-0,090.

Smörjning: Denna typ är underhållsfri och skall inte smörjas.